

Kayline

TOPS for the "JEEPSTER COMMANDO"

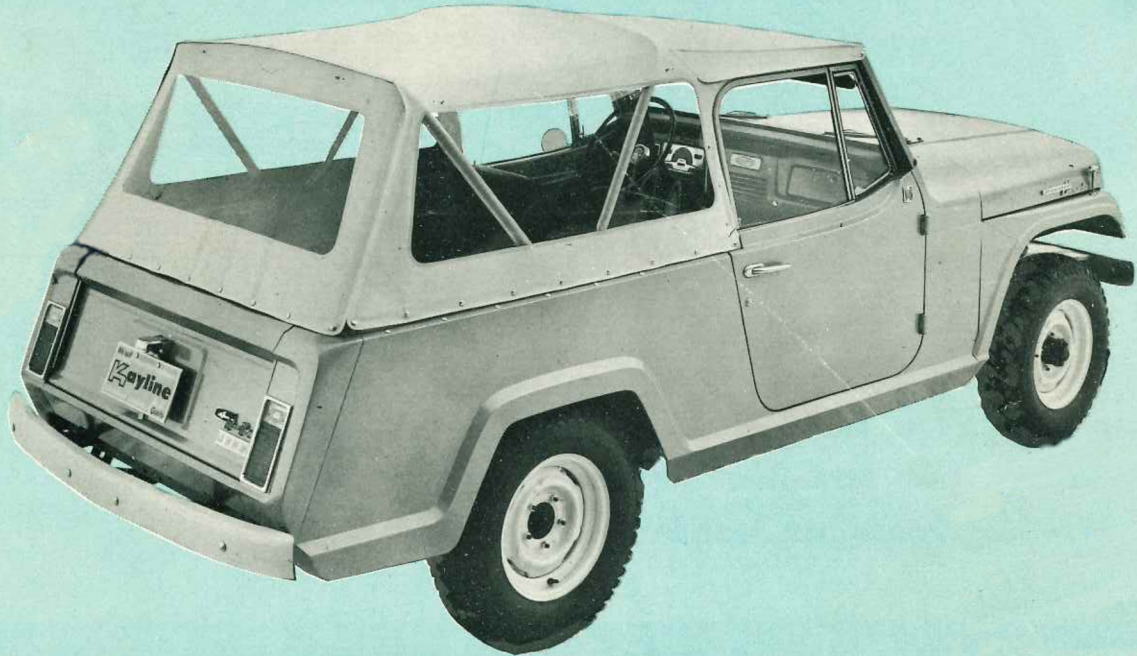

TOPS for the "JEEP" UNIVERSALS



"OUR BUSINESS IS TOPS"

"KAYLINER" CONVERTIBLE



Model Shown
C-5-L



VERSATILE YET PRACTICAL



- Full Vision Rear View Window
- Zippered Roll-Up Side and Rear Panels
- Zippered Window Doors are Standard Equipment

STANDARD FULL TOP



MODEL SHOWN F-5-C

Standard full top in White Vinyl-faced topping, with standard doors. Also available in Black Vinyl at no additional cost.

"LUXAIR"

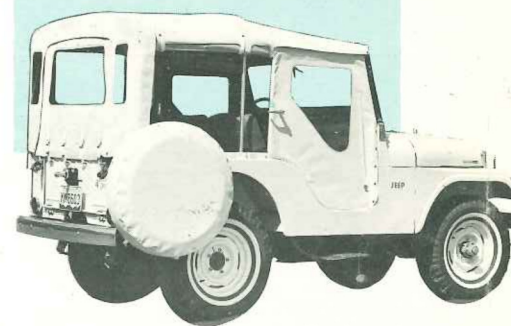

ALL KAYLINE TOPS OFFER T

- ★ Top Seams and Glasses Electronically welded to insure a strong, air-tight bond that eliminates wicking and leaking of moisture.
- ★ Styled from Vinyl-coated, Preshrunk, Scotchgarded, Waterproof sports topping.
- ★ Chrome outside door handles.
- ★ Glasses of stain resistant AS-6 Vinyl approved in all states.
- ★ Brass zipper in rear curtain, brass buckles and cadmium-plated hardware to resist rust and corrosion.

ALL MODEL KAYLINE TOPS AVAILABLE IN RED, BLUE, GREEN, TURQUOIS

KAYLINE DOUBLE WINDOW CONVERTIBLE

ONLY KAYLINE CONVERTIBLES HAVE . . .

Our exclusive Bow Release Bracket eliminates the difficult task of trying to refasten snaps after top has been in down position. By releasing the bows the entire top sags, enabling all snaps to be fastened with ease. With all snaps fastened, engage the bow release mechanism and your Kayline top snaps into a taut, attractive enclosure with a minimum of effort.



MODEL SHOWN C-5-D

Double window convertible in white vinyl. Also available in Black Vinyl at no additional cost. With zippered door glass as shown optional at slight additional cost.

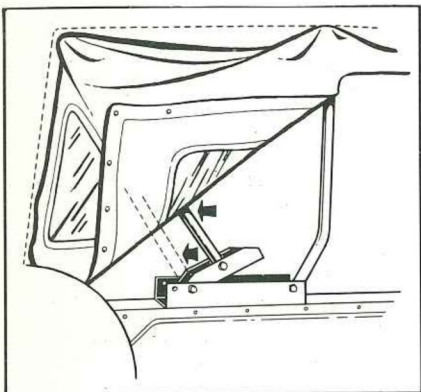

FULL TOP

FEATURING

- ★ Maximum ventilation with maximum shade.
- ★ Zip open side panels for quick and easy side loading accessibility.
- ★ Sides roll up and strap in place.
- ★ Quick change from a warm winter enclosure to a cool summer top.

KAYLINE HALF TOP

*STANDARD • CONVERTIBLE



MODEL SHOWN H-5-C

Half-top in White Vinyl sport topping with standard doors.

- * Standard when installed on vehicle with regular Half Top Bows.
- Convertible when installed with the new KAYLINE Convertible Half Top Bows.

THESE OUTSTANDING FEATURES

- ★ Exclusive quick fastening device over windshield for easy lowering of top on convertibles and half tops (except CJ-2A and Military).
- ★ Large glass areas for unrestricted visibility. White topping has black interior for less glare — less soil.
- ★ Stitched with Durable Dacron Thread.
- ★ Top Kit complete with all mounting hardware.
- ★ Vinyl surface easily cleaned with non-detergent soap.
- ★ Easy installation, with detailed instructions, for all models.

AND TAN VINYL ON SPECIAL ORDER AT SLIGHT ADDITIONAL COST

"JEEPSTER" CONVERTIBLE

Model Shown
C-101



FEATURING

- Metal door header for weathertight seal between door glass frame and top.
- Drip rail and rain diverter over doors.
- Quick fastening device over windshield for easy lowering of top.
- Concealed zipper installation at rear corners to lessen chances of water leaks.
- Roll-up side and rear panels for open air fair weather driving.
- Extra large glasses for unrestricted visibility.
- Exclusive bow release brackets.
- Easy, uncomplicated installation.

Jeepster Half Top and Tonneau Covers



Model Shown
Half Top H-101
Tonneau T-101-C

For utility yet attractive in appearance, Kayline offers this unequalled combination convertible half top and Tonneau cover. Notice the excellent visibility, the trim fit, a drip rail and rain diverter over the doors, roll-up rear center curtain with concealed zippers and design so as not to interfere with the attractive Jeepster lines . . . Remember also, this half cab employs a metal header against which the door glass frame closes to facilitate a tight weather seal. While the Tonneau cover is matched and integrated with the top to provide cargo protection against the elements, it is a separate item and must be ordered separately. Of course, this means the convertible half top can be purchased separately.



Model Shown
Tonneau T-101-M

For Cargo protection with the metal half cab of the "Jeepster Pickup," Kayline offers a Tonneau cover designed specifically for this adaptation. Easily installed and being quickly removable for access, it is functional as well as attractive. Low in cost, this is a most desirable accessory.

OPTIONAL DOORS

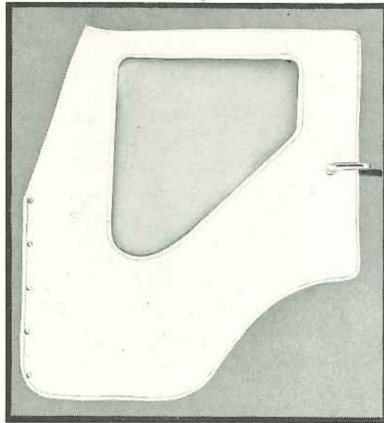

STANDARD DOORS

Included with each Kayline Top unless otherwise specified.

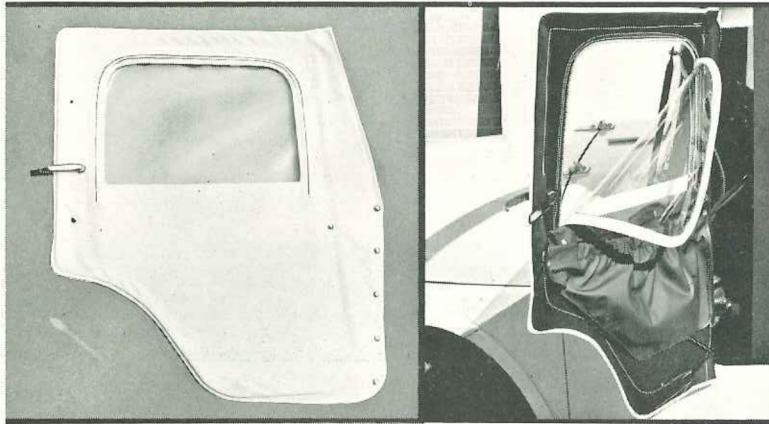

ZIPPERED WINDOW DOOR

For quick easy ventilation and added convenience, the glass area zips out on three sides.

No storage problem here as the zipped out glass folds down into a convenient storage pocket.

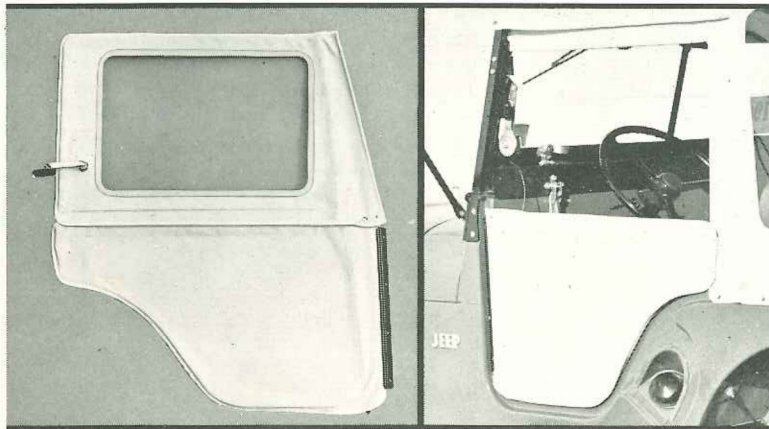

DUTCH DOORS

A two-piece door arrangement that is both practical, versatile, and easily stored.

Remove top half for maximum ventilation and retain bottom half for safety.

Rear Seats — Bench Pads

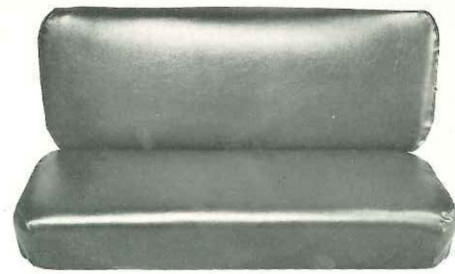

Part No.
RS-Standard

STANDARD:

- For ALL Universal Jeeps.
- Deep coil springs in all models.
- Rubberized hair and firm Polyfoam padding.
- Sisal layered for durability and comfort.
- Long-wearing fabric supported plastic upholstery.
- Black, red, metallic blue and rawhide.

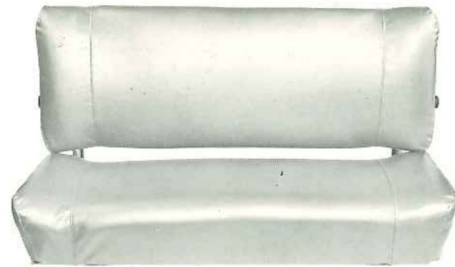

Part No.
RS-5-6

Part No.
RS-101

DELUXE:

- For CJ-5, CJ-6 and Jeepster Commando.
- Reversible — faces either forward or backward after installation.
- Back lifts and folds down flat, increases cargo area, in either position.
- Black, red, metallic blue and rawhide.

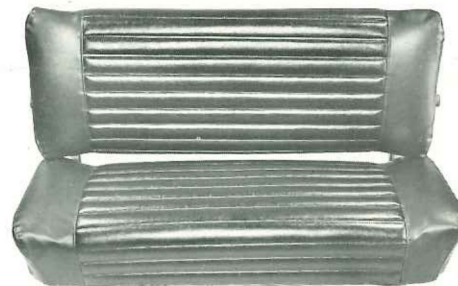

Part No.
RS-5-6 RP

Part No.
RS-101 RP

DELUXE ROLLED AND PLEATED:

- For CJ-5, CJ-6, and Jeepster Commando.
- Same features as Deluxe.
- Black only.



Standard
Part No. BP

Colors:
Red
Black
Metallic Blue
Rawhide

- Comfortable-filled with 3-inches of firm Polyfoam!
- Snap in position over wheel housings.
- Easy to install.



Deluxe
Part No.
BP-R&P
Color:
Black only
Rolled and Pleated

Kayline

ACCESSORIES



JEEPSTER COMMANDO

Model No. TCC-101



TIRE AND CAN CARRIER

(Cans Not Included)

JEEP UNIVERSAL

Model No. TCC-Univ.

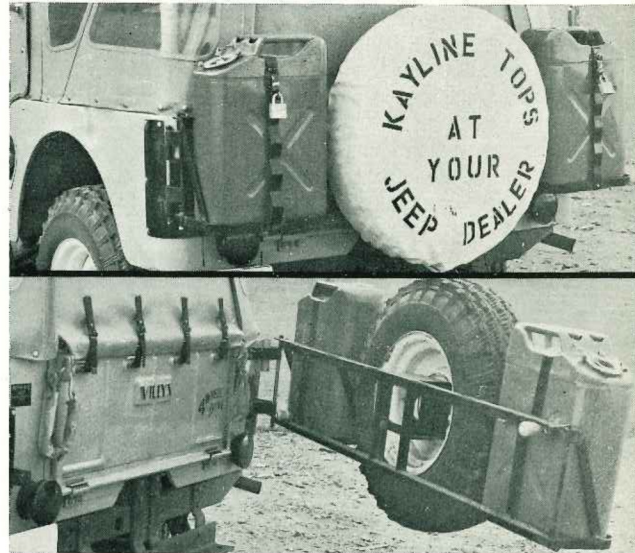

- Durable all steel construction, permanently mounted, nothing to work loose
- Easily installed by one person
- Permits easy access to tailgate
- Holds 1 standard 5-gal. can, and spare tire up to 30" in diameter
- Adds less than 10 inches at tailgate
- Two lock points prevent theft
- Outside tire mount gives more cargo space inside vehicle
- Shipping weight 38 pounds
- Kit complete with all mounting hardware

- Sizes for all Jeeps, state Model. Shipping weight 34 lbs. Does not obstruct rear view or tail-lights. Tow bar clearance is more than adequate
- Holds standard cans, tire size up to 29½" Outside Diameter
- Leaves sides clear for narrow passages, adds less than ten inches at tailgate
- Easy access to tailgate
- Three lock points prevent theft
- Can be mounted by one person
- Durable all-steel construction
- Wrap-around brackets attach permanently, become virtually one with body shell, will not tear out or work loose

STEEL TOOL BOX

Locking

(For Use With TCC-101 Only)



- Mounts neatly in frame on carrier.
- Lid swings up for easy access.
- Water and dust resistant.
- 9" wide, 9¼" tall, 24" long.

DOOR STORAGE BRACKETS

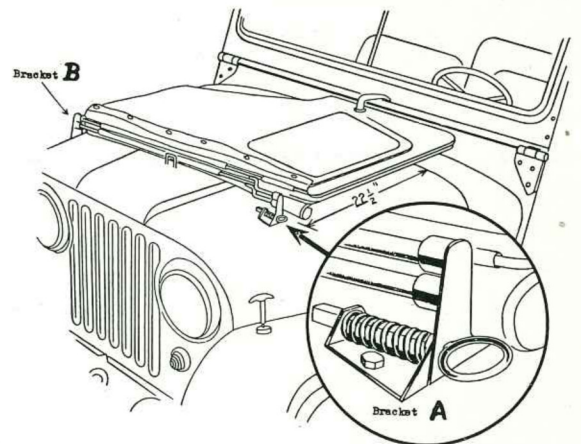

- Convenient "out of the way" Door Storage
- Fits all Jeep Universal Models except Military and C-J-2A

EAST OF MISSISSIPPI AND EXPORT:
KELLY MANUFACTURING CO.
 503 Broad Street — Charleston, W. Va. 25301

WEST OF MISSISSIPPI:
KAYLINE MANUFACTURING CO.
 5611 Raritan Road — Denver, Col. 80221

DEALER